



1718 W. Fullerton Chicago, IL 60614  
 Ph: 773.770.1195 • Fax: 773.935.5613  
 www.PureEdgeLighting.com • info@PureEdgeLighting.com  
 © 2016 PureEdge Lighting. All Rights Reserved.

## Installation Instructions for 1" Rectangle Canopy & J-Box

C-1RE-JBOX

CV2-1RE-JBOX-50W-IC

### IMPORTANT INFORMATION

- This instruction shows a typical installation.

**SAVE THESE INSTRUCTIONS!**

## Install the Junction Box

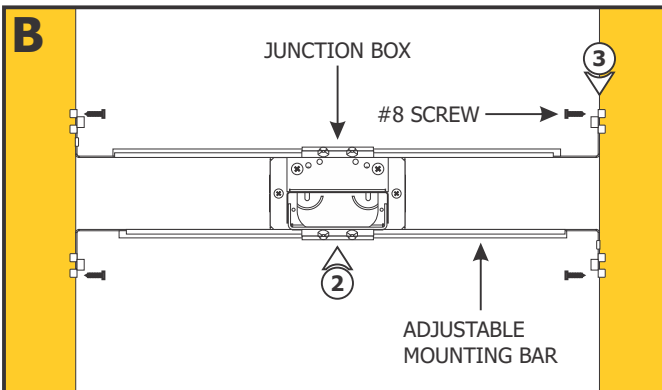
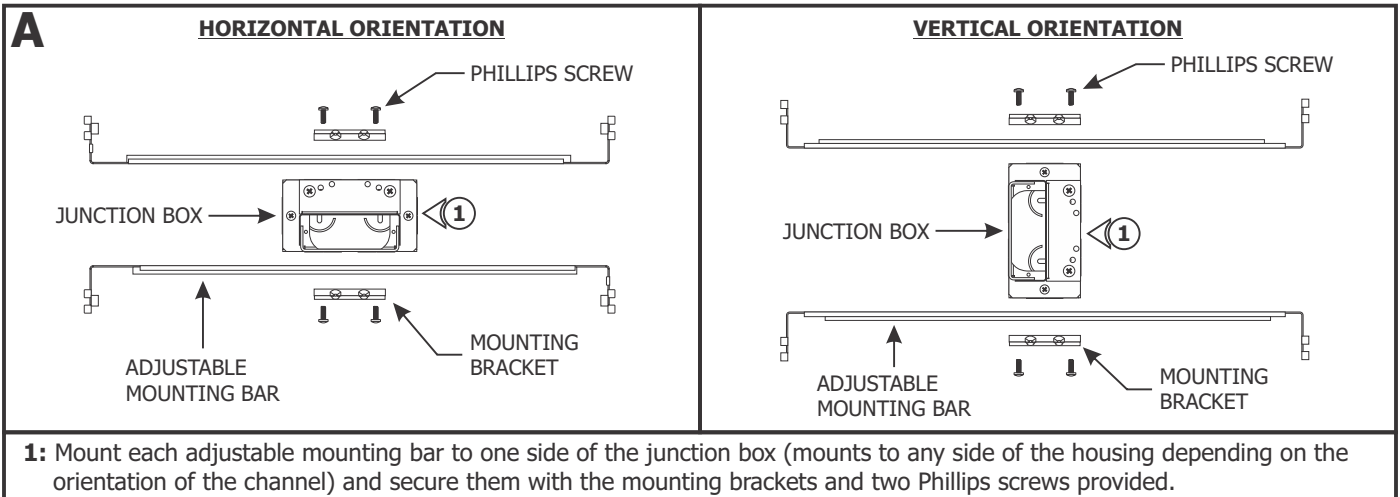

**NOTE:** Adjustable mounting bars mount to studs that are spaced 14.5" to 25" apart.

- 2:** Select the location between the two studs for the junction box to be mounted.
- 3:** Place the adjustable mounting bar tabs between the studs. Secure the adjustable bars to the studs with the #8 screws.

**4:** Remove a knockout to install a conduit into the junction box. Install conduit(s) (if required by local electrical code).

**5:** Run the 120V power wires to the junction box.

**6:** If using remote power supply, then run the low-voltage 24VDC power wires coming from the remote power supply to the junction box.

**NOTE:** Ensure remote power supply wires are present in the junction box. Refer to instructions provided with the power supply.

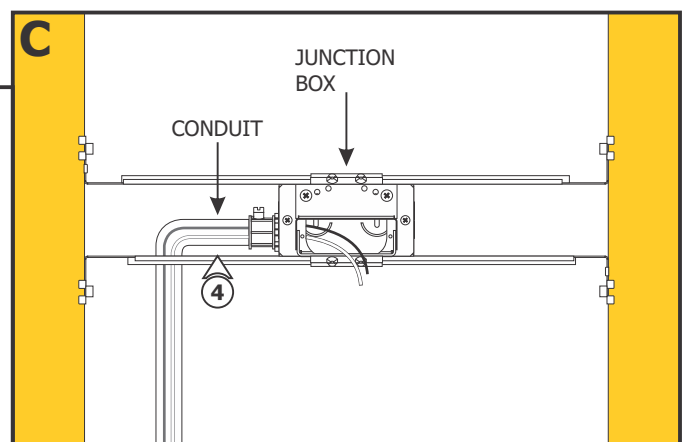

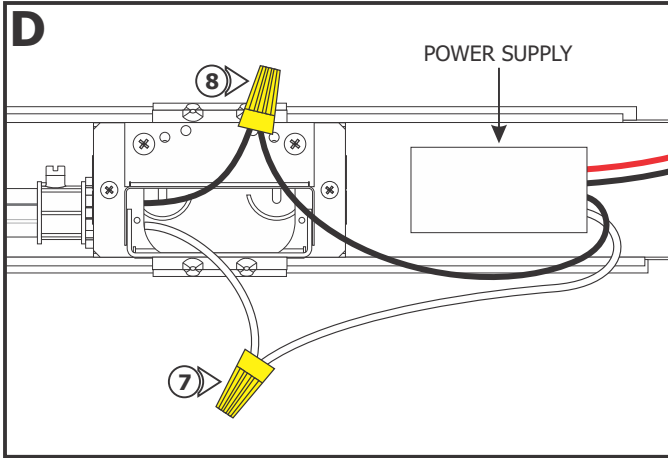

**NOTE:** Steps 7 through 9 are for 1" Rectangle Canopy & J-Box with 50W Power Supply. Omit these steps if using remote power supply.

**NOTE:** Make sure the junction box is grounded in accordance to local electrical codes.

**7:** Connect the neutral wire from the 120VAC circuit to the white wire of the power supply using a wire nut.

**8:** Connect the hot wire from the 120VAC circuit to the black wire of the power supply using a wire nut.

**9:** Place the power supply and wires inside the junction box.

**10:** Mark a rectangle shape on the drywall where the junction box opening will be located depending on selected position.

**11:** Cut out the marked rectangle opening, using a "Dremel Multi-Max" with the "wood & drywall" cutting bit.

**12:** Install & finish drywall.

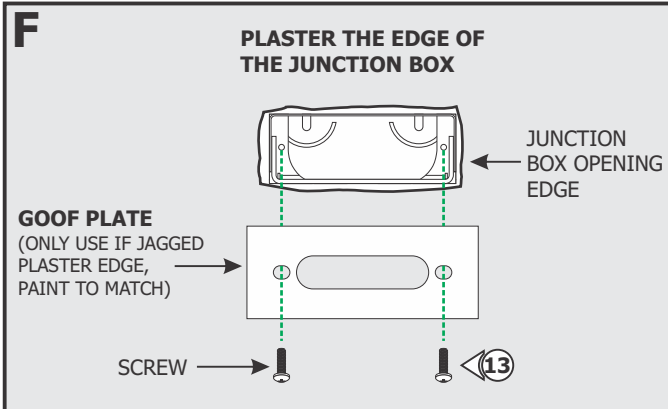
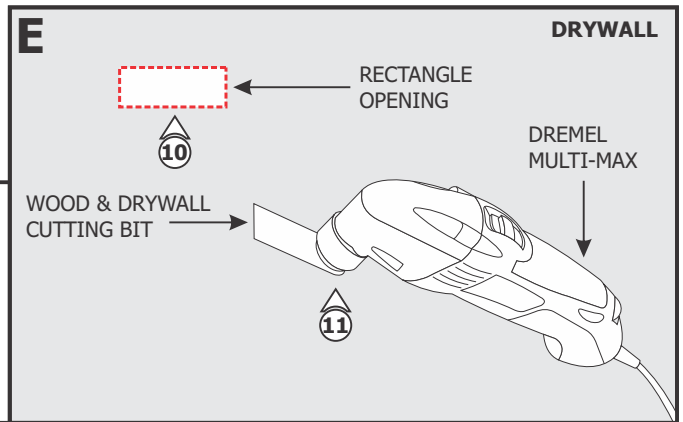

**13: Optional:** Use the Goof Plate if the junction box opening has imperfection/ jagged edges. Install the provided goof plate (paint to match prior) with the two screws.