

Installation Instructions for **150 Watt Remote Magnetic Transformer** **230 Volt Input to 12 Volt Single Feed Output**

SAVE THESE INSTRUCTIONS!

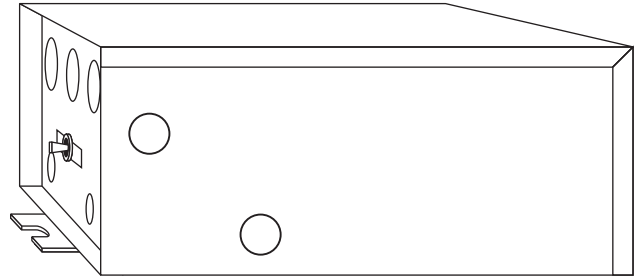

GENERAL INFORMATION

- **RISK OF FIRE:** This product must be installed by a qualified electrician. Turn the power to the electrical box off during installation. Read the "Important Safety Instructions " before installation.
- This product is suitable only for indoor dry locations and approved for the use at any height above the finished floor.
- This product may be dimmed only with a low voltage magnetic dimmer. Using a dimmer other than specified may work initially, but will eventually cause transformer failure and void the warranty. The dimmer must be derated as indicated by the dimmer manufacturer.
- A typical installation is shown. Specific installation must be in accordance with the local electrical codes.
- **TO REDUCE RISK OF FIRE,** it is important to wire the remote transformer for the system as described in this installation instruction.
- Load the circuit of the remote transformer to **MAXIMUM 150** Watt.

IMPORTANT SAFETY INSTRUCTIONS

- Do not install this lighting system in a damp or wet location.
- Do not conceal or extend bus bar conductor through building wall.
- To reduce the risk of fire and burns, do not install this lighting system where the insulated open bus bar conductors can be shorted or contact any conductive materials.
- To reduce the risk of the system overheating and possibly causing a fire, make sure all the connections are tight.
- Do not install fixture assemblies closer than six inches or as specified in the fixture installation instructions to curtains or similarly combustible materials.
- Turn the electrical power off before modifying the lighting system in any way.
- The fixtures used with the Edge Lighting systems must be identified for use with the corresponding Edge Lighting systems.
- Minimum volume of the electrical box must be 6 cubic inches (98 cubic centimeters).
- The system is "ETL" listed for USA and Canada only when all the products used are supplied by Edge Lighting.

Install the Remote Transformer

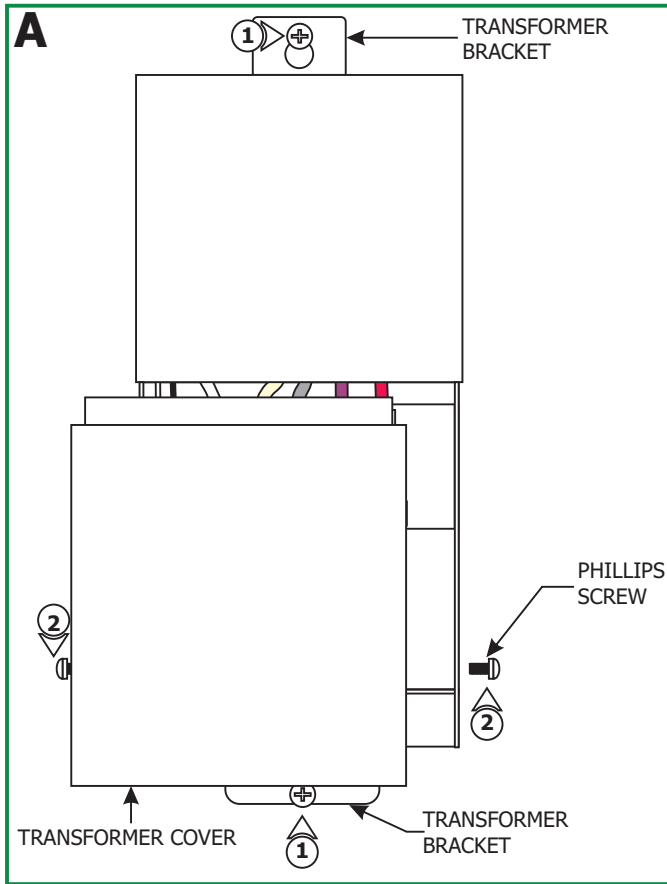

NOTE: In order to use small gauge wires from the transformer to the electrical box, it is recommended to install the remote transformers as near as possible to the electrical box. See "Low Voltage Wire Size Chart" below.

- 1:** Use the transformer brackets to secure the transformer in place (hardware not included).
- 2:** Loosen and remove the two Phillips screws on the sides of the transformer to remove the transformer cover.

- 3:** Install a conduit and power wires from the panel to the transformer.
- 4:** **DO NOT** connect the power wires to the panel at this time.
- 5:** Connect the 230V black transformer wire to the hot power with a wire nut.
- 6:** Connect the 230V white transformer wire to the neutral power with a wire nut.

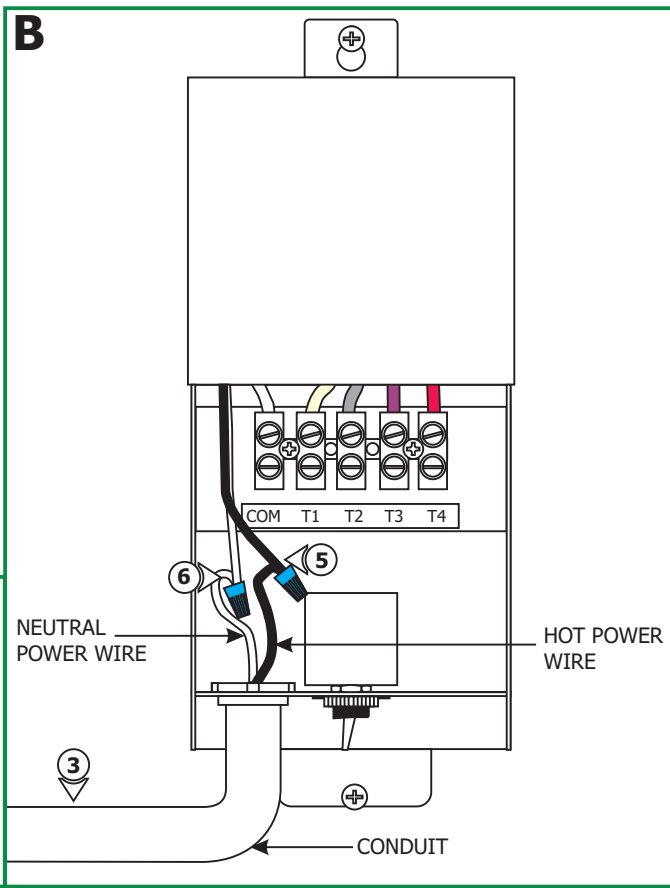

LOW VOLTAGE WIRE SIZE CHART

TRANSFORMER WATTAGE	WIRE SIZE FOR 5 FT	WIRE SIZE FOR 6-15 FT	WIRE SIZE FOR 16-20 FT	WIRE SIZE FOR 21-40 FT
150 WATT	#12 GA	#8 GA	#6 GA	#4 GA

C

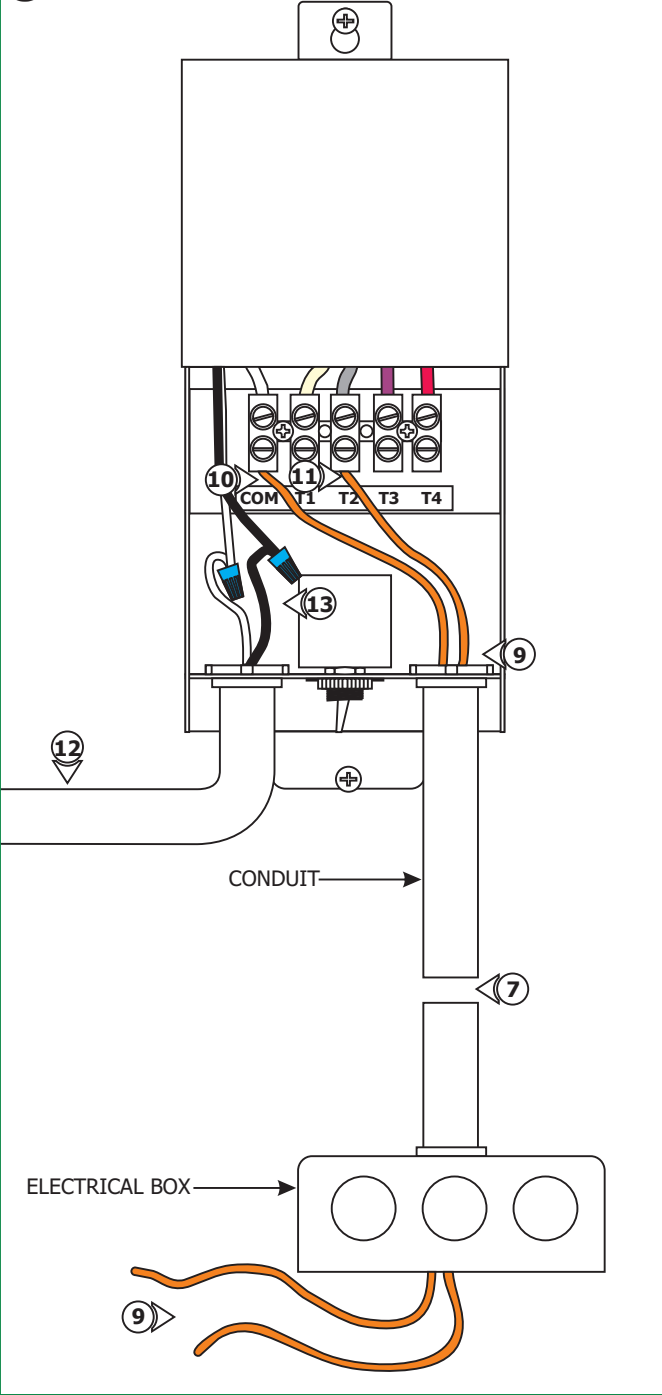

7: Install a conduit from the transformer to the electrical box.

8: For the best performance, use the "Low Voltage Wire Size Chart" on page 2 to select the wire size.

NOTE: Using a smaller wire size other than specified will result in a increase in voltage drop and will reduce the lamp intensity.

NOTE: The THHN wire sizes specified in "Low Voltage Wire Size Chart" are for 3% or less drop in voltage based on 150 watt loads. Lengths are the distance from the remote transformer to the system power feed connector, or power feed canopy.

9: Install the THHN low voltage wires from the transformer to the electrical box where the power feed will be installed.

10: Insert one low voltage wire into the terminal marked "COM" and tighten the screw firmly.

11: Insert the second low voltage wire into the "T2" terminal tap (default) and tighten the screw firmly.

12: At this time, connect the 230 volt power wires at the panel.

13: Measure the voltage at the power wires coming into the transformer. If the voltage is not in the range of 201-220 volt, then pick the proper terminal tap using the "Terminal Tap Chart" below to reconnect the second low voltage wire.

NOTE: Risk of Fire - The terminal taps **ARE NOT** for boosting the transformer low voltage power, they are selected to ensure output power voltage based upon input power voltage condition. **NEVER** use a higher terminal tap to compensate for voltage drop, this will overheat the low voltage wires and transformer. It is recommended to use the wire size as indicated in "Low Voltage Wire Size Chart" on page 2 to avoid excessive voltage drop.

TERMINAL TAP CHART	
PRIMARY POWER INPUT VOLTAGE	TERMINAL TAP TO BE USED
175-183	T4
184-200	T3
201-220	T2
221-225	T1

D

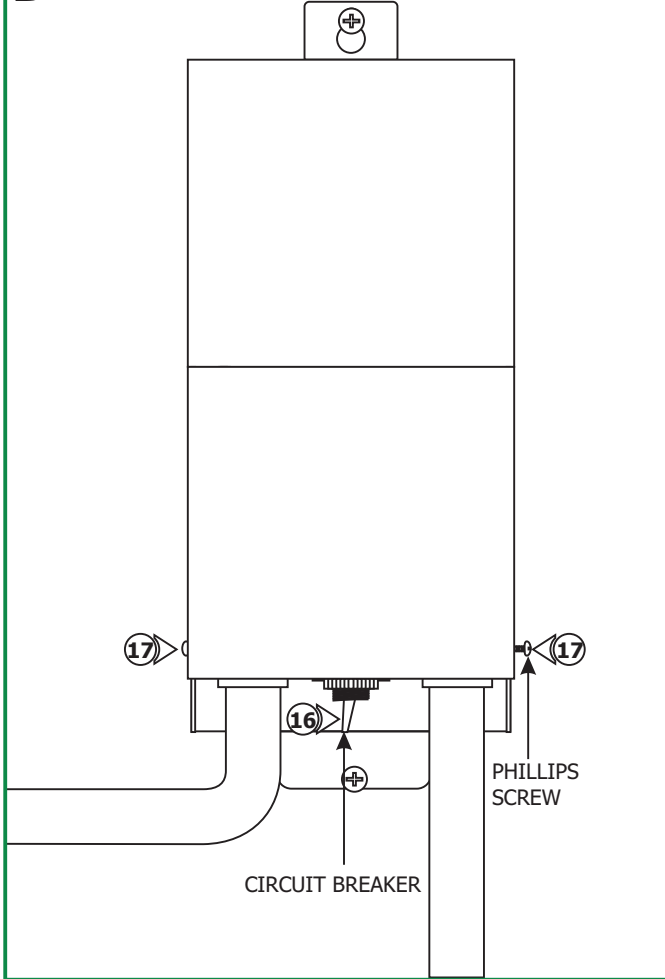

14: After installing the entire low voltage system, if the lamps have low intensity, then measure the voltage at the fixture closest to the power feed contacts with a voltmeter. The system must be at least 80% loaded and the voltmeter should read between 11V-12V ~AC. If the voltage does not fall in this range, call Edge Lighting "Technical Support" at 773-770-1195.

15: After operating the system for a few minutes, on the low voltage side, all electrical connection points should be no more than warm to the touch. If a connection is hot to the touch, retighten the connection and check to ensure that the temperature decreases.

16: The transformer circuit breaker will trip if there is a short in the system. After removing the cause of the short, reset the circuit breaker to power the system.

17: Replace the transformer cover and tighten the two Phillips screws on the sides of the transformer.