

## Installation Instructions for Monorail 4" Round Single Power Feed Canopy

### IMPORTANT INFORMATION

- This product is ETL listed for indoor dry locations.
- This product can be installed to a 4" electrical box with round plaster ring, or to an octagon electrical box.
- Minimum electrical box volume must be 6 cubic inches (98 cubic centimeters).
- This product should be installed by a qualified electrician.

**SAVE THESE INSTRUCTIONS!**

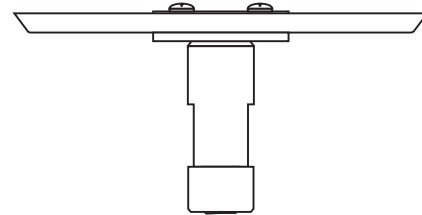

### Install the Canopy

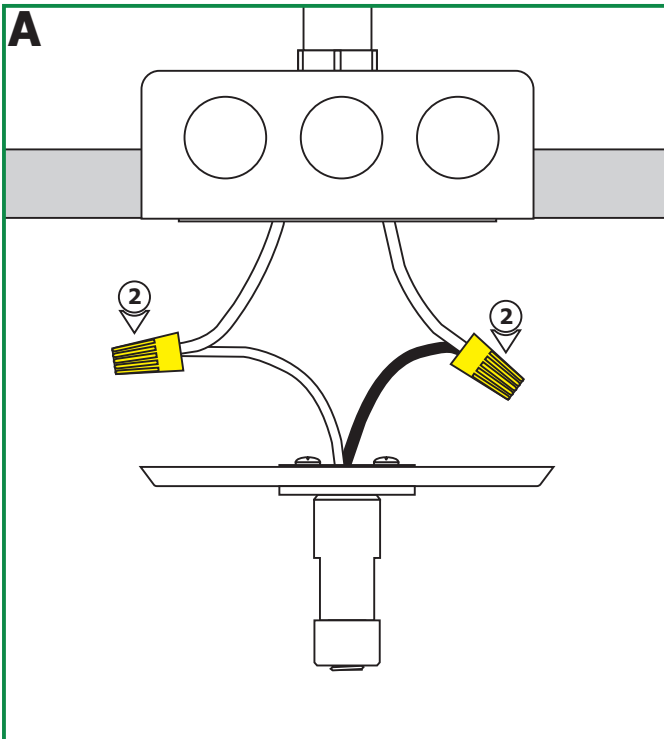

**NOTE:** Use the universal round crossbar (provided) if the electrical box holes are not spaced 2-3/4" apart.

**NOTE:** The low voltage wires should be present in the electrical box. Refer to the instructions provided with the remote transformer to install the transformer and the low voltage wires before proceeding with the steps below.

**1:** Turn the power to electrical box off.

**2:** Connect each low voltage wire coming from the remote transformer to one power feed canopy wire with a wire nut.

**3:** Place all wires inside the electrical box.

**4:** Secure the power feed canopy to the electrical box by tightening the two provided #8-32 screws with the 3/32 Allen wrench.

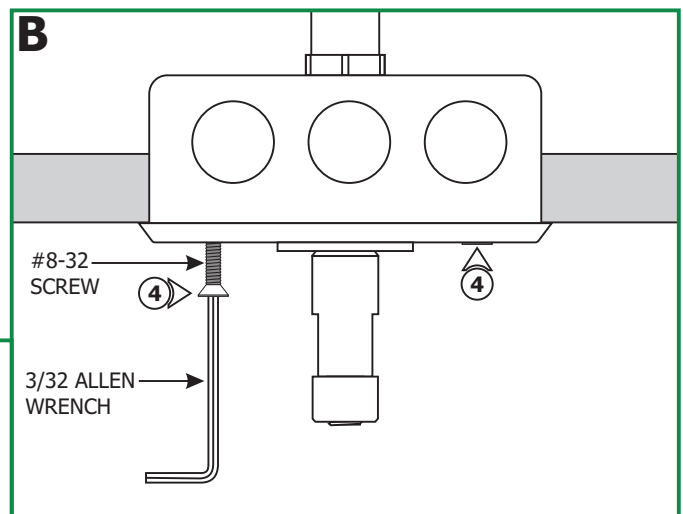

# Install the Monorail to Power Feed Canopy

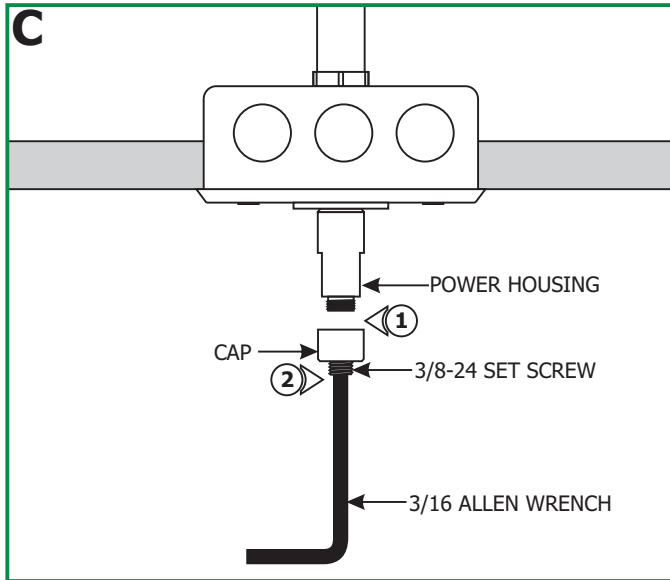

**1:** Unscrew the cap from power housing.

**2:** Slightly loosen the 3/8-24 set screw on the cap with the 3/16 Allen wrench provided, **DO NOT REMOVE IT.**

**3:** Place the Monorail into the power housing. Make sure that the Monorail is supported by the standoffs. Refer to the instructions provided with the standoffs.

**4:** Tighten the cap to the power housing. **Make sure the cap is not cross threaded.**

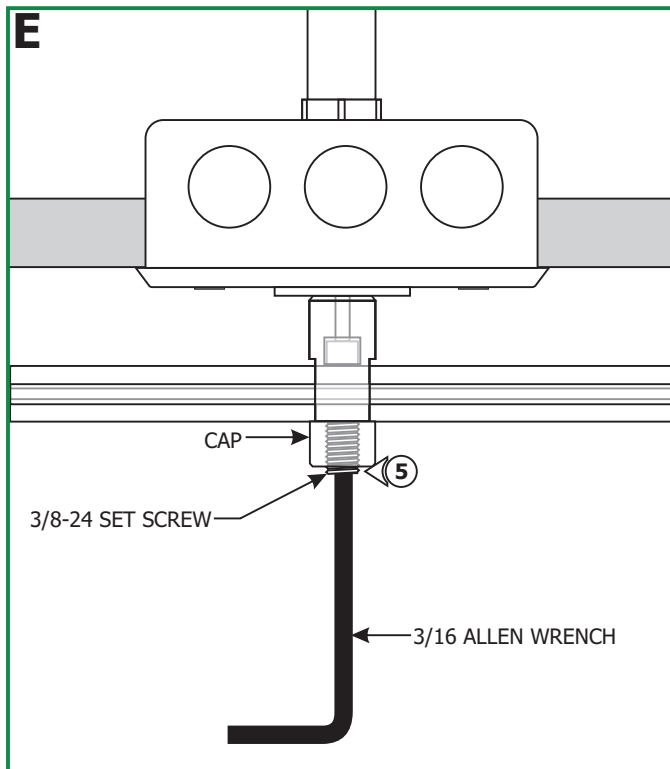
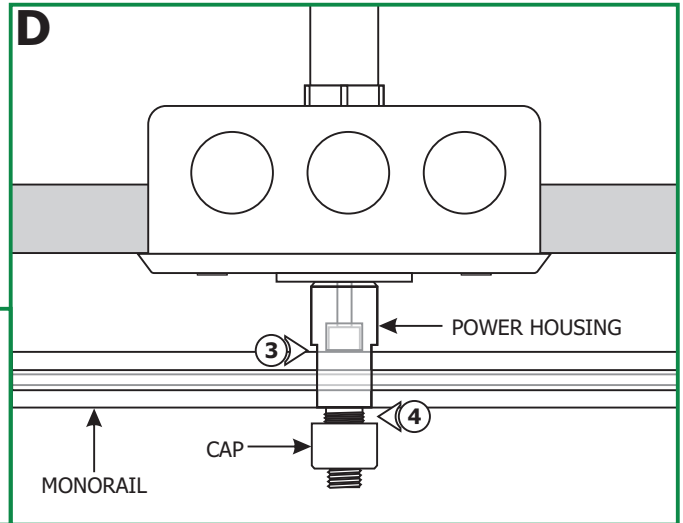

**5:** Tighten the 3/8-24 set screw on the cap firmly with the 3/16 Allen wrench provided for proper power connection.