

Installation Instructions for Fast Jack Power Round & Square 4" Flat Canopies

IMPORTANT INFORMATION

- This product is ETL listed for indoor dry locations.
- This product is dimmable with a standard incandescent dimmer.
- This product can be installed to a 4" electrical box with round plaster ring, or to an octagon electrical box.
- Minimum electrical box volume must be 6 cubic inches (98 cubic centimeters).

SAVE THESE INSTRUCTIONS!

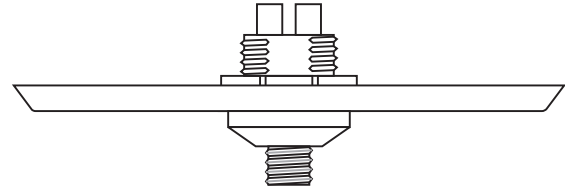

Install the Canopy

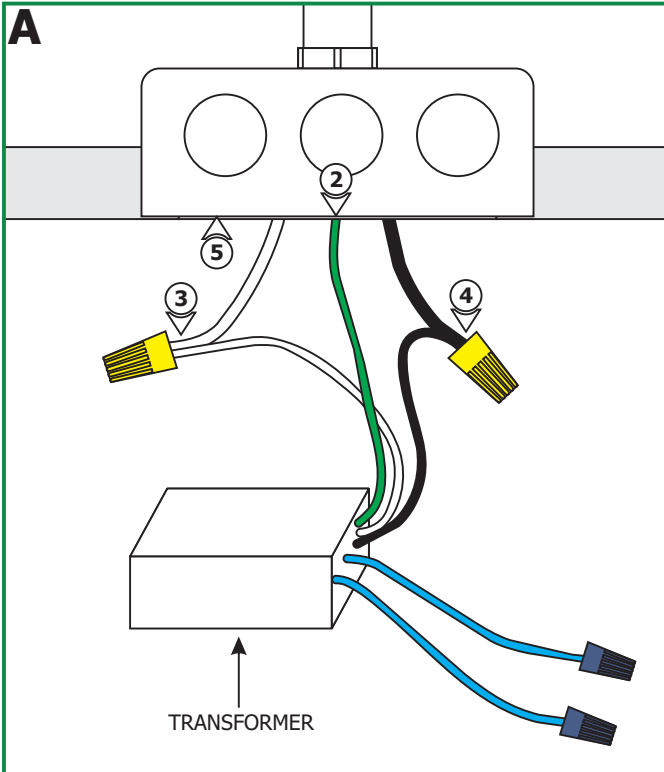

- 1: Turn the power to electrical box off.
- 2: Connect the green transformer wire to the ground in accordance with local electrical codes.
- 3: Connect the white transformer wire to the neutral power wire with a wire nut.
- 4: Connect the black transformer wire to the hot power wire with a wire nut.
- 5: Place the transformer and transformer wires inside the electrical box.

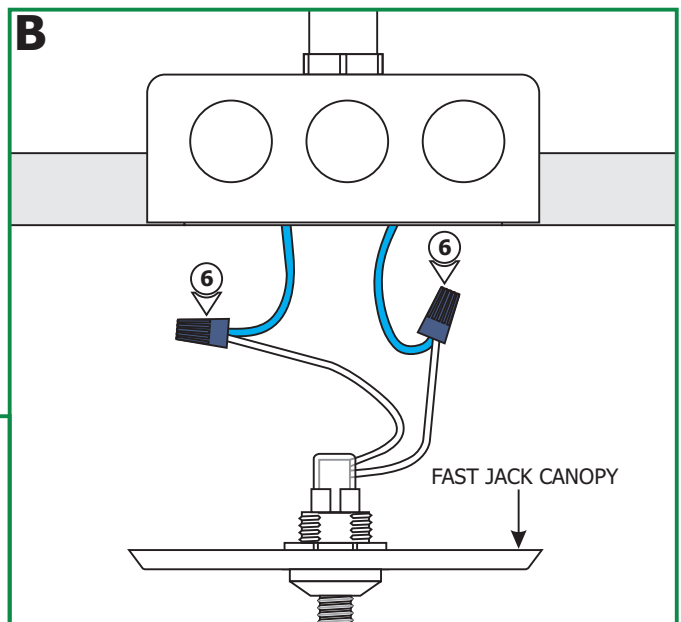

NOTE: Use the universal round crossbar (provided) if the electrical box holes are not spaced 2-3/4" apart.

- 6: Connect each Fast Jack canopy wire to one low voltage transformer wire with a wire nut.

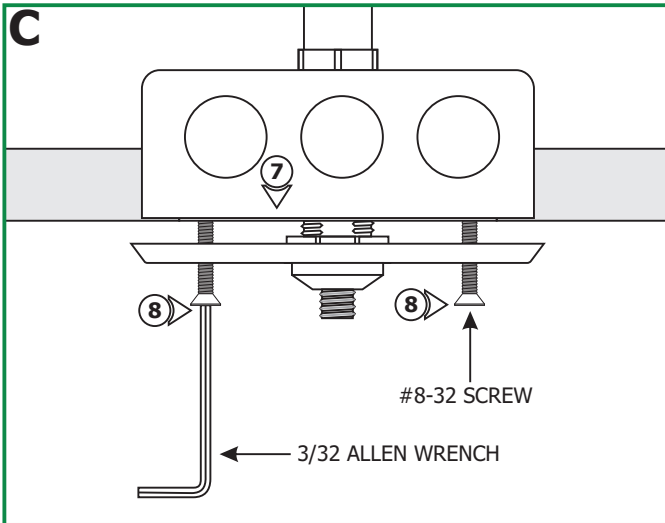

7: Place all wires inside the electrical box.

8: Secure the Fast Jack canopy to the electrical box by tightening the two provided #8-32 screws with the 3/32 Allen wrench.

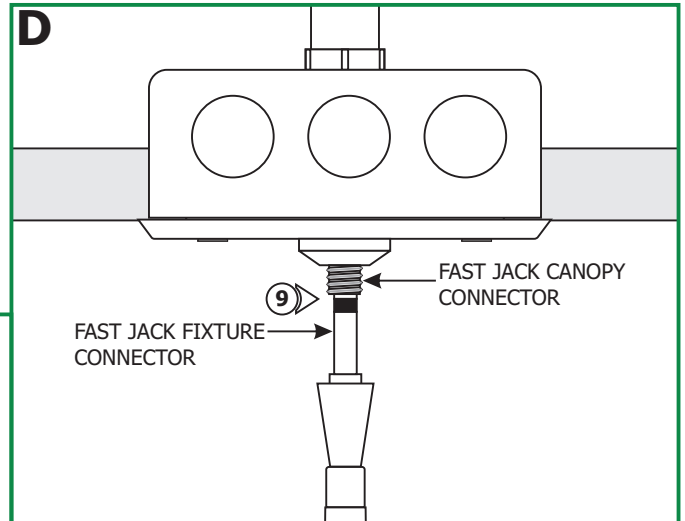

CAUTION: Risk of Fire: MAX load of Fast Jack canopy is **75** watt.

9: Use fingers to tighten the Fast Jack fixture connector into the Fast Jack canopy connector.