



### Surface Mount Transformer with Fast Jack Connector

Monorail surface mount magnetic transformer with integral Fast Jack connector in the center allowing for installation of one Fast Jack fixture in the middle of the canopy.

#### Dimmable:

With LV Magnetic Dimmers

#### Compatible Accessories or Finished Items:

All Fast Jack fixtures

#### Finish:

Satin Nickel, Polished Nickel or Antique Bronze

#### Weight:

150 Watt: 7 lb (2.6 kg)  
 300 Watt: 12 lb (5 kg)  
 600 Watt: 20 lb (7.5kg)

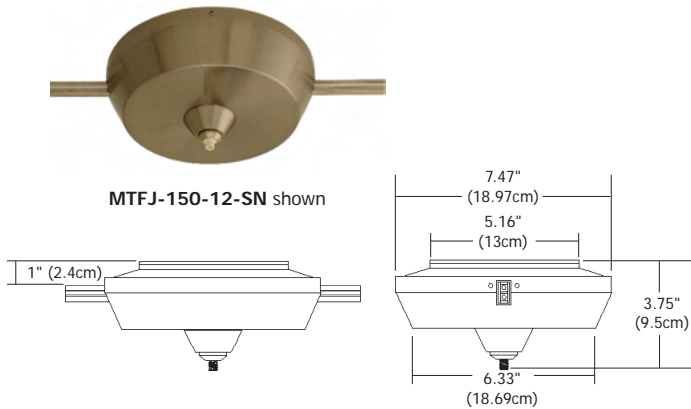

MTFJ-150-12-SN shown

System	Power Type	Output Type	Finish	Input Type
<b>MTFJ</b>	<b>150</b>	<b>12</b>	<b>SN</b>	Standard 120 Volt (leave blank)
MTFJ Monorail Surface Mount Magnetic Transformer with Fast Jack Connector	150 150 Watt	12 12 Volt Single Feed	SN Satin Nickel PN Polished Nickel BZ Antique Bronze	2 230 Volt

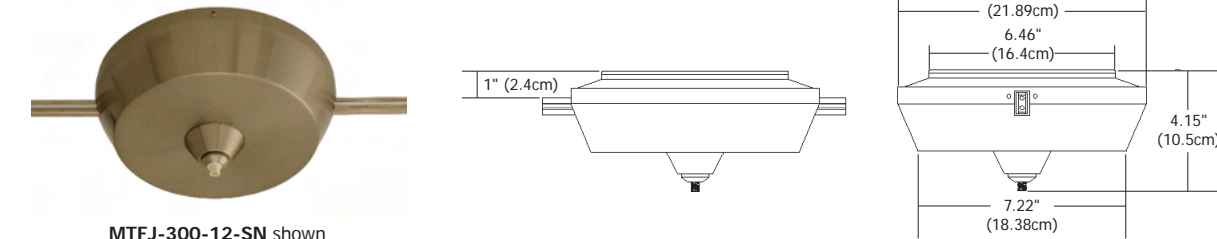

MTFJ-300-12-SN shown

System	Power Type	Output Type	Finish	Input Type
<b>MTFJ</b>	<b>300</b>	<b>12</b>	<b>SN</b>	Standard 120 Volt (leave blank)
MTFJ Monorail Surface Mount Magnetic Transformer with Fast Jack Connector	300 300 Watt	12 12 Volt Single Feed 24 24 Volt Single Feed	SN Satin Nickel PN Polished Nickel BZ Antique Bronze	2 230 Volt

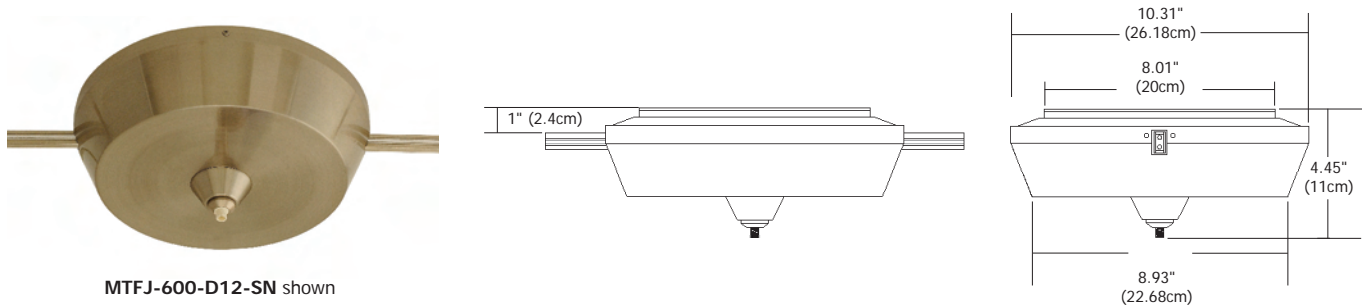

MTFJ-600-D12-SN shown

System	Power Type	Output Type	Finish	Input Type
<b>MTFJ</b>	<b>600</b>	<b>24</b>	<b>SN</b>	Standard 120 Volt (leave blank)
MTFJ Monorail Surface Mount Magnetic Transformer with Fast Jack Connector	600 600 Watt	24 24 Volt Single Feed D12 12 Volt Dual Feed	SN Satin Nickel PN Polished Nickel BZ Antique Bronze	2 230 Volt

PROJECT: \_\_\_\_\_ FIXTURE TYPE: \_\_\_\_\_ DATE: \_\_\_\_\_