

Installation Instructions for Fast Jack Kiki Pendant

IMPORTANT SAFETY INSTRUCTIONS

To reduce the risk of fire, electrical shock, exposure to excessive UV radiation, or injury to persons:

- Use this fixture indoors only.
- Do not look directly at the lamp while the fixture is on.
- **RISK OF FIRE:** Use only the type of lamp and maximum wattage indicated in this instruction manual.
- Never cover the halogen lamp with anything other than a lamp shield provided by Edge Lighting and never place flammable material close to the fixture.
- Never turn the fixture on and off by connecting and disconnecting the halogen lamp.
- Do not touch the fixture head, shade or lamp shield while the fixture is on. These surfaces may be **VERY HOT**.
- Do not touch lamp at anytime. Use a soft cloth instead as oil from skin may damage lamp.
- It is normal for a new halogen lamp to produce minor smoke when first turned on.
- Do not operate the luminaire with a missing or damaged shield.
- Turn power off and allow to cool before replacing lamp.

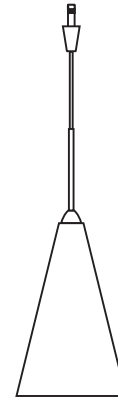

IMPORTANT INFORMATION

- This product is ETL listed for indoor dry locations and approved to be used at any height above the finished floor.

SAVE THESE INSTRUCTIONS!

Adjust the Fixture Height

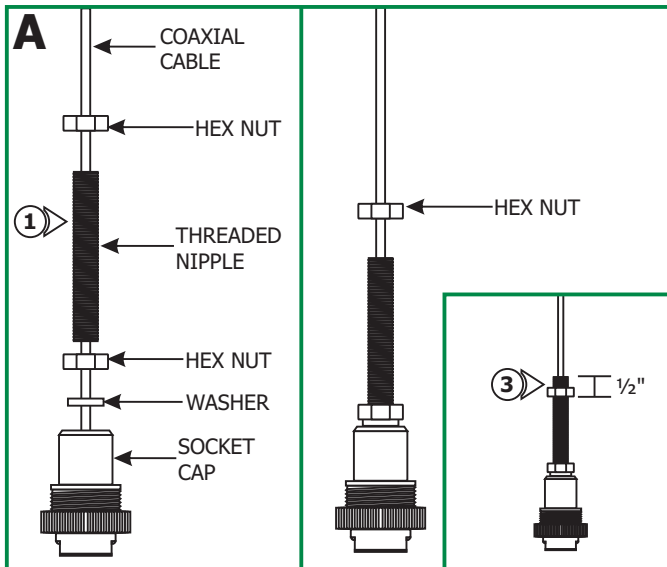

- 1:** Feed the coaxial cable through the threaded nipple, hex nuts, washer and another hex nut respectively.
- 2:** Tighten the threaded nipple to the socket cap and secure it in place with the first hex nut and washer.
- 3:** Screw the second hex nut 1/2" below top of the threaded nipple. Slide the washer down and tighten the third hex nut so that the washer is placed between the two hex nuts.

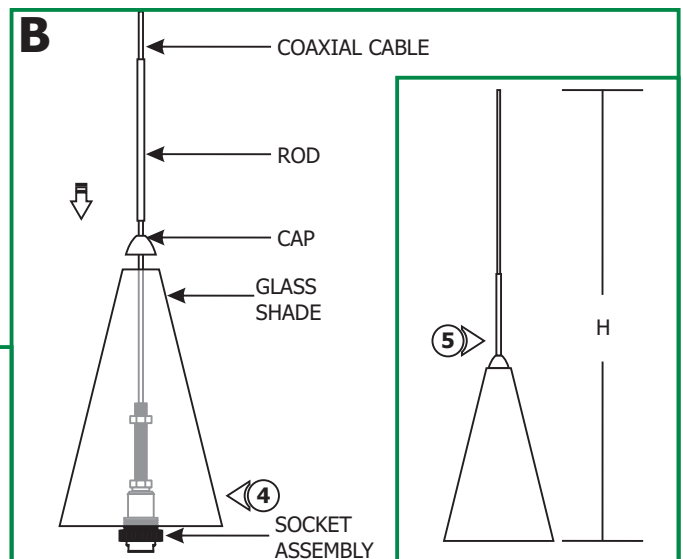

- 4:** Feed the coaxial cable through the glass shade, cap and rod respectively and carefully slide them down onto the socket assembly.
- 5:** Cut the coaxial cable to the desired height (H) with a sharp cutter. The overall fixture height is measured from the bottom of the glass shade to the end of the coaxial cable.

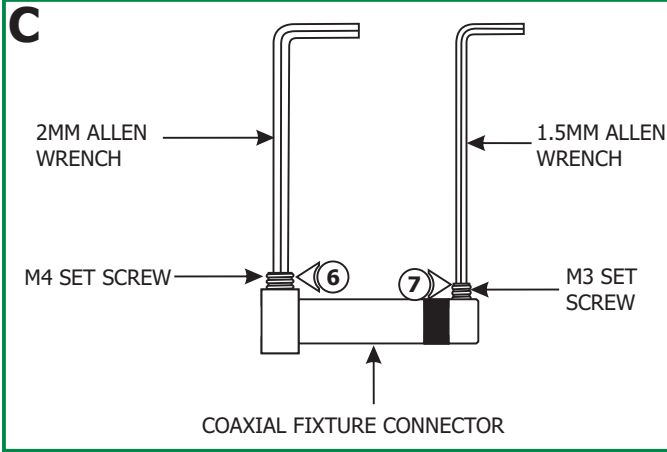

6: Loosen the M4 set screw on base of the coaxial fixture connector with the 2mm Allen wrench provided. **Do not remove this set screw.**

7: Remove the M3 set screw on tip of the connector with the 1.5mm Allen wrench provided.

8: Use the #12 gauge hole of the AWG wire strippers to strip 1" of the insulation cover from the end so that the bare coaxial cable is exposed.

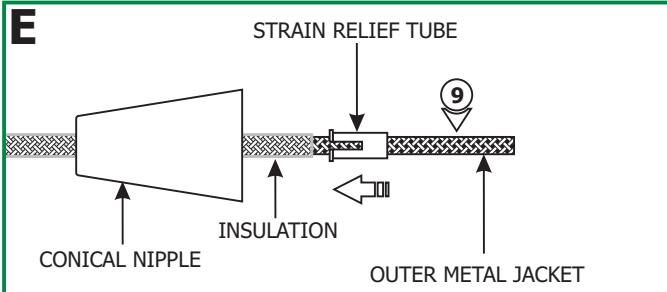
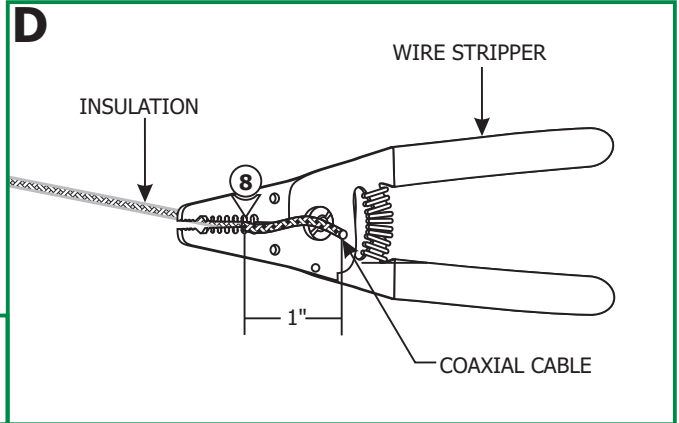

9: Feed the coaxial cable through the conical nipple and flared side of the strain relief tube. Slide the conical nipple down the coaxial cable. Slide the strain relief tube against the insulation.

10: Use the #14 gauge hole of the AWG wire strippers to strip the outer metal jacket exposed behind the strain relief tube.

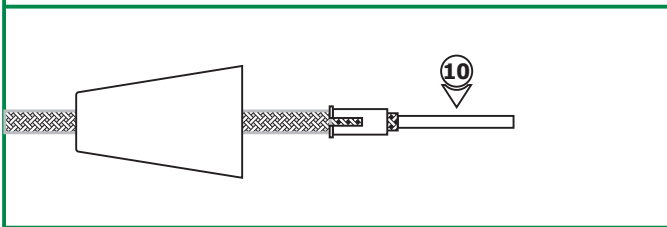

11: Feed the inner coaxial cable along with strain relief tube into the coaxial fixture connector.

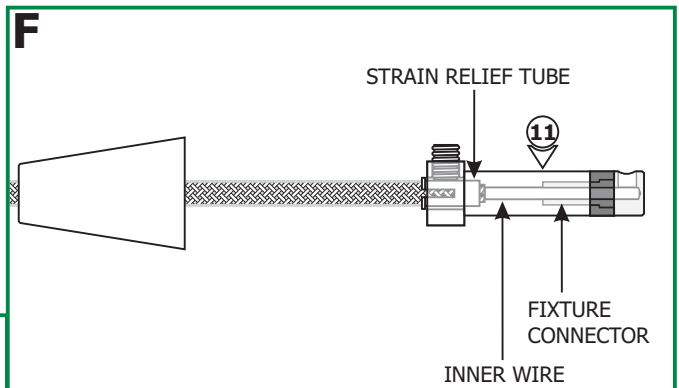

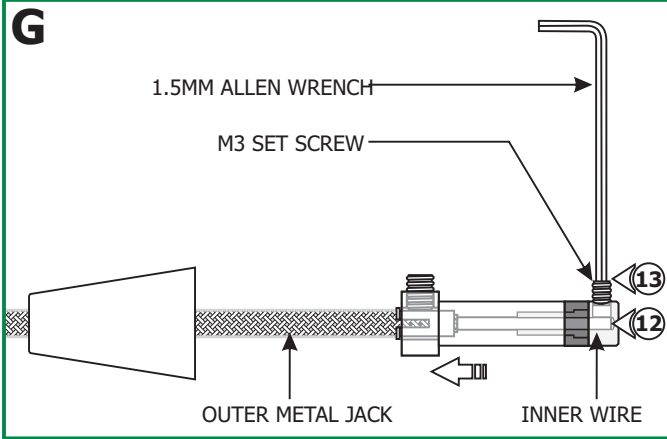

12: Keep feeding the coaxial cable in until the inner wire is visible in the screw hole of the fixture connector tip.

13: Hold the fixture connector and coaxial cable in place. Replace and tighten the M3 set screw on fixture connector tip with the 1.5mm Allen wrench.

14: Make sure the strain relief tube is completely into the coaxial fixture connector and the slot on the strain relief tube is not inline with the M4 set screw.

15: Tighten the M4 set screw with the 2mm Allen wrench.

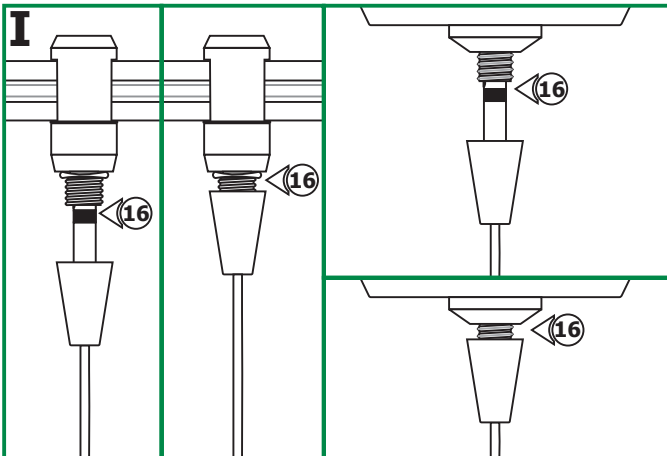
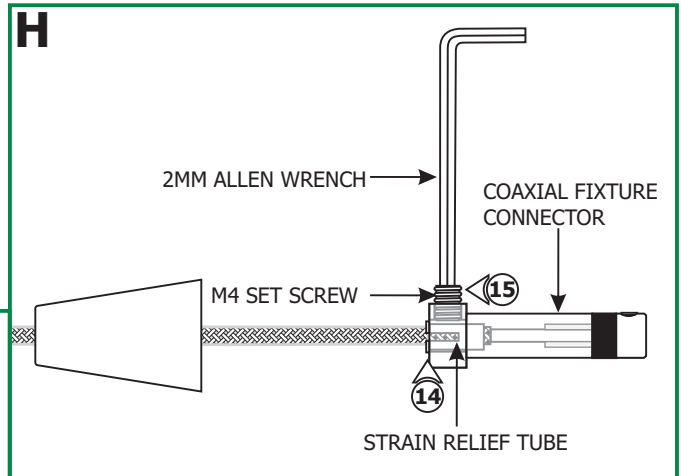

16: Use fingers to tighten the Fast Jack fixture connector into the Fast Jack system connector (Monorail, Monorail 2 Circuit, or canopy connector - Refer to the instructions provided with the system connector or canopy).

17: Refer to the instructions provided with the Monorail 2 Circuit fixture connector to choose Circuit #1 or Circuit #2.

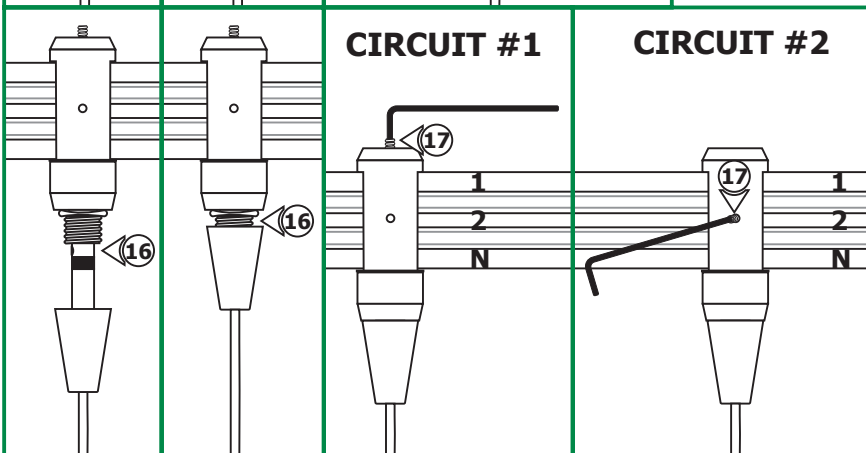

Install the Lamp

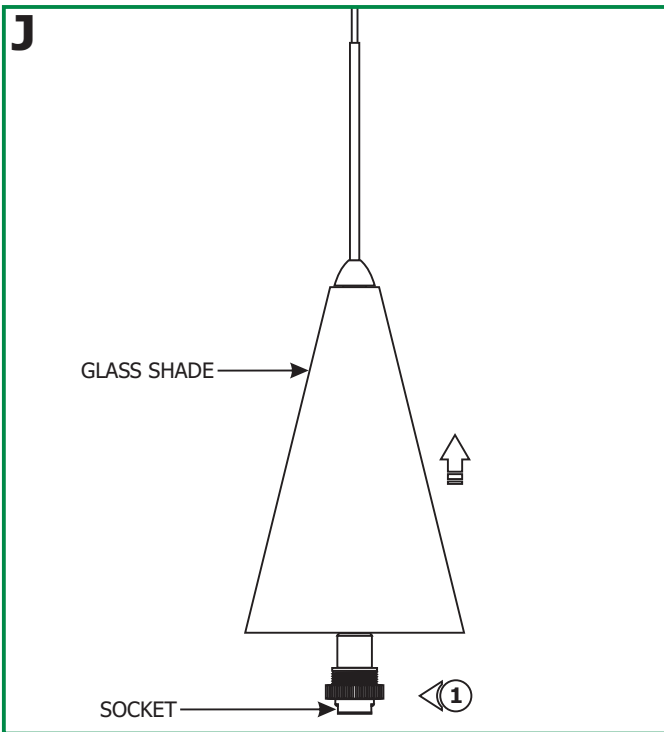

CAUTION: To reduce risk of a burn or electrical shock during lamping, disconnect the power to the fixture.

1: Lift the glass shade up to expose the socket.

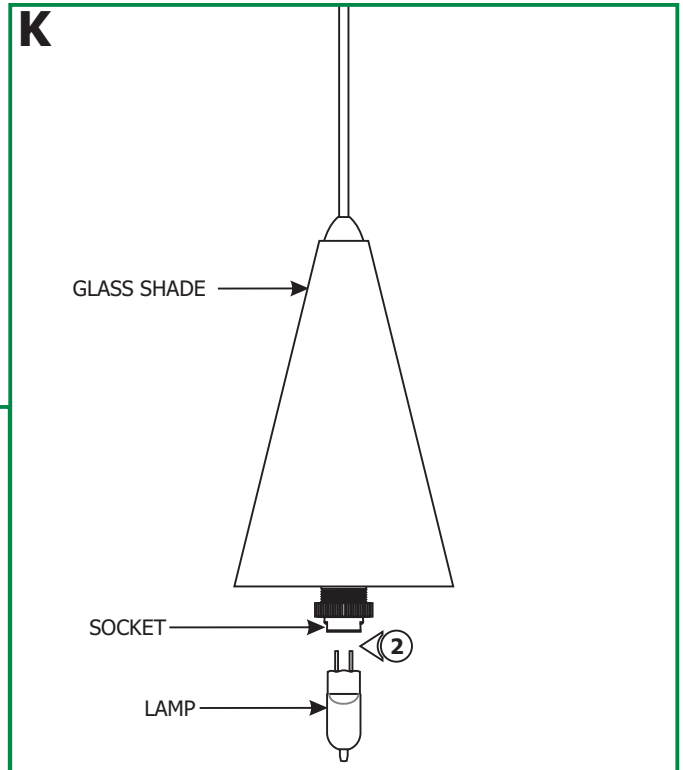

WARNING: RISK OF FIRE

Never replace a Xenon (Xelogen) lamp with a regular Halogen lamp. A regular Halogen lamp requires a protective lamp shield.

NOTE: Use only fingers and a soft cloth to install the lamps.

Use **MAX 50 Watt Bi-Pin Xenon (Xelogen) Lamp**, or low pressure halogen lamp specified by manufacturer  to be used with unshielded (without lamp shield) fixture.

2: Push the lamp pins completely into the socket holes.

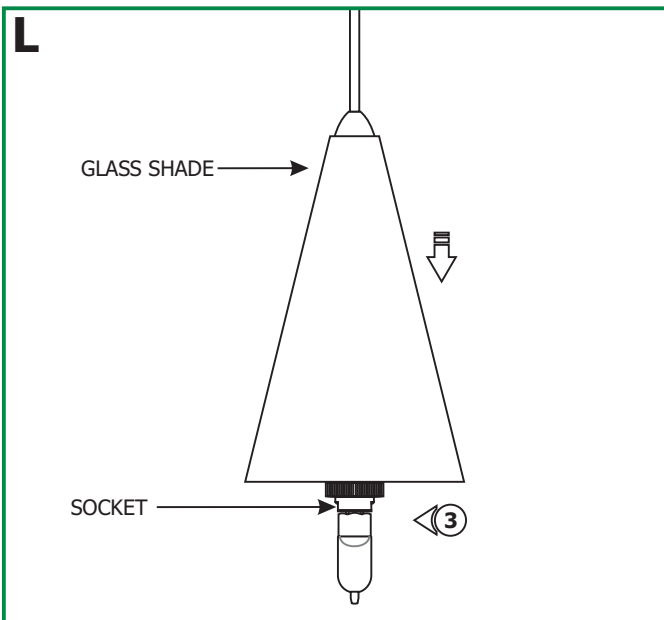

3: Lower the glass shade onto the socket assembly.