

Installation Instructions for **DIAL LED**

IMPORTANT INFORMATION

- **RISK OF FIRE:** This product must be installed 4 ft above the ground for wet locations.
- This product is for wall mount applications only.
- This product can mount to a standard 4" electrical box with a plaster ring or an octagon electrical box.
- This product is not dimmable.

SAVE THESE INSTRUCTIONS!

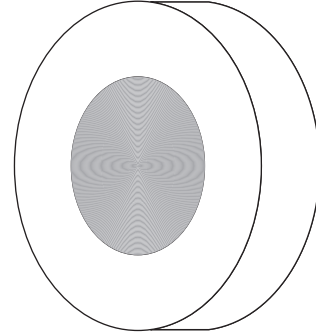

Disassemble the Fixture & Install the Driver

A

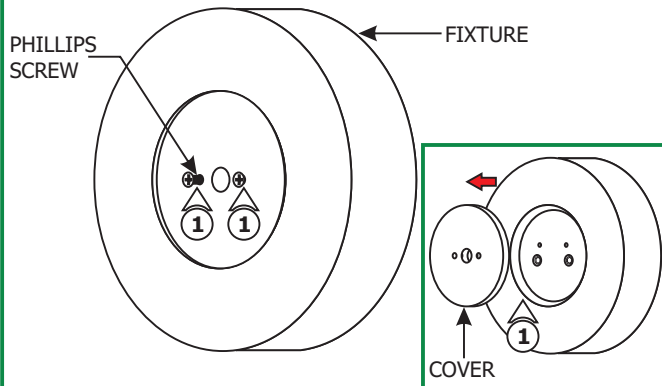

1: Loosen the two Phillips screws to remove the cover.

B

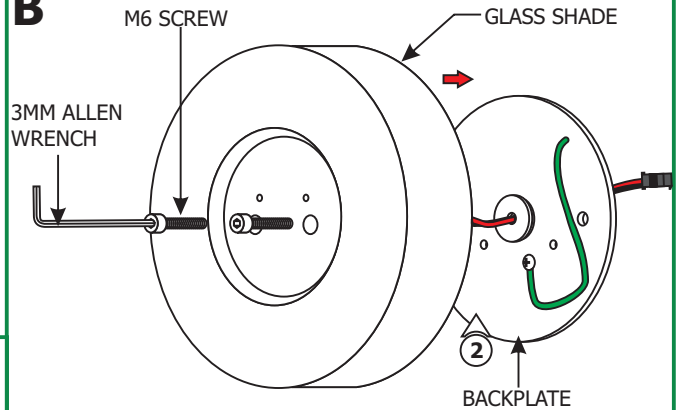

2: Loosen the two M6 screws using the provided 3mm Allen wrench to remove the backplate.

C

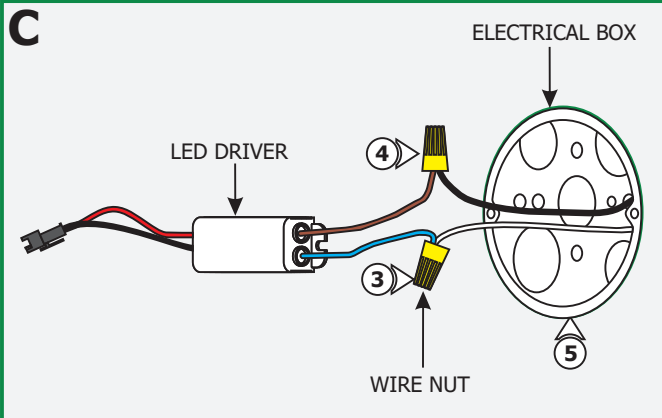

3: Connect the blue (NEUTRAL) LED driver wire to the neutral power wire with a wire nut.

4: Connect the brown (HOT) LED driver wire to the hot power wire with a wire nut.

5: Place the LED driver and wire connections inside the electrical box.

Install the Fixture

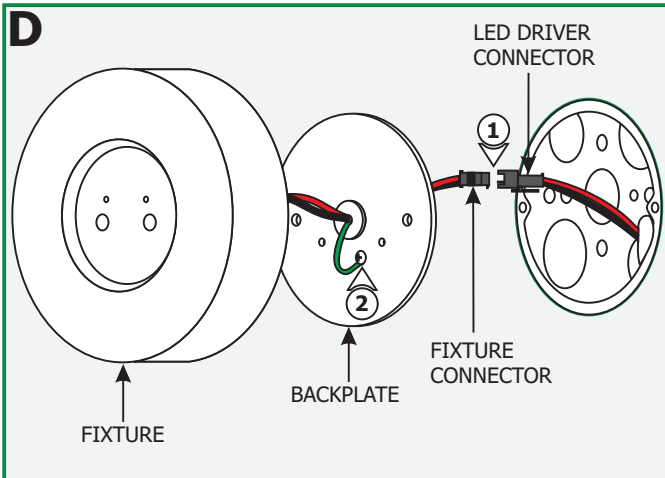

NOTE: Use the universal crossbar (provided) when mounting the fixture to an octagon box. There will be a 1/16" gap between the fixture and the wall when the universal crossbar is used. Caulking around the fixture will be needed when the universal crossbar is used in outdoor applications.

- 1: While holding the fixture, snap the fixture connector to the LED driver connector making sure the connectors are locked in place.
- 2: Make sure the backplate is grounded in accordance with local electrical codes.

3: Align the two inner threaded screw holes on the backplate toward bottom for the LEDs to light towards top of the wall or toward the top for LEDs to light towards bottom of the wall.

4: Mount the backplate to the electrical box holes with the two #8-32 screws provided.

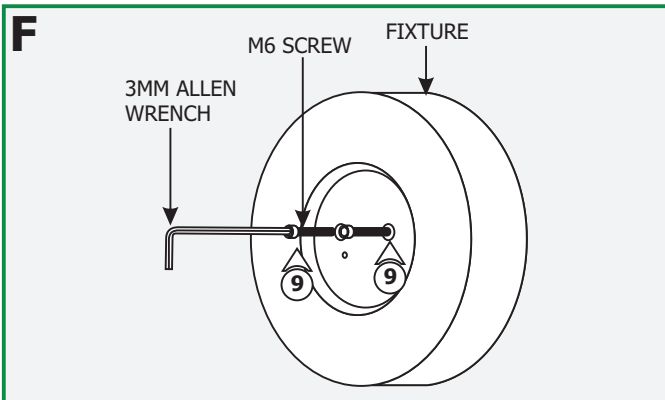
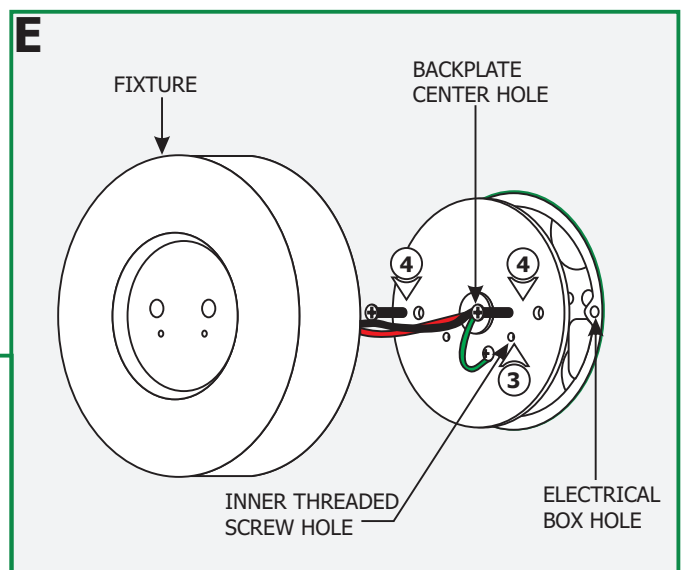

5: Place the fixture completely onto the backplate. Replace and tighten the two M6 screws with 3mm Allen wrench.

6: Replace the cover and secure it to the fixture with the two Phillips screws.

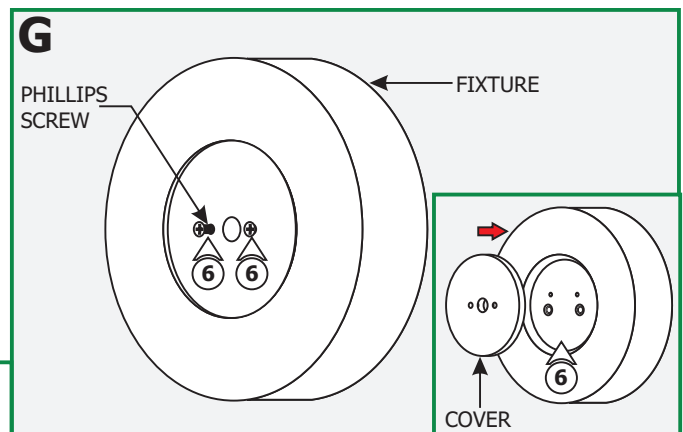

H

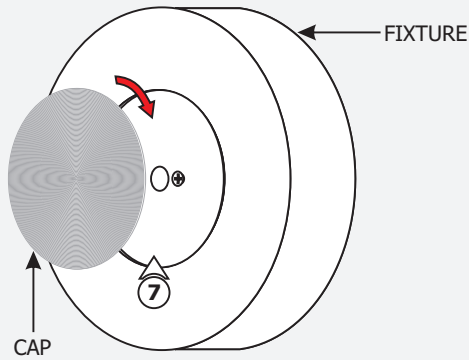

7: Tighten the cap onto the fixture to cover the screw holes.

I

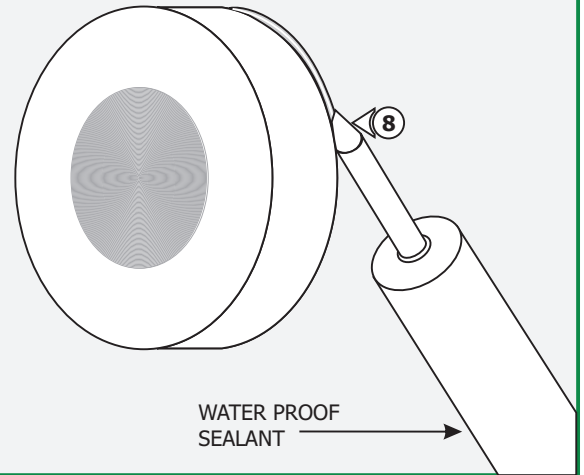

8: For Outdoor Installation: Caulk around the fixture canopy with a water proof sealant.

NOTE: The fixture contains integrated LED lamps rated for 40,000 hours. It consumes a total of 3 watts.